







# Assembly Instruction

CH107W01E2DW  
URBANDALE SIDE CHAIR

## HARDWARE PARTS:

						
Pan Head Screw 4 pcs	(Short) JCBC Bolt 2 pcs	(Long) JCBC Bolt 8 pcs	Lock Washer 10 pcs	Flat Washer 10 pcs	Allen Key 1 pce	Glue 1 pce

## ASSEMBLY:

- Position the Chair Back on a soft surface such as a carpet. Place the Box System Assembly (Hardseat is pre- attached to the seat frame in assembly) on to the middle rail of the Chair Back with the dowel fully inserted into the pre-drilled hole.
  - Insert **JCBC Bolt (Long)** through a **Lock Washer** and a **Flat Washer** into the pre- drilled holes on the rear corner block of the seat frame.
  - Insert the **JCBC Bolt (Short)** through a **Lock Washer** and a **Flat Washer** through the rear pre-drilled holes on the seat frame.
- Apply **Glue** to all the pre-drilled holes before attaching all Stretchers. Insert each Side Stretcher into pre-drilled holes on both of the Rear Legs, make sure that screw hole on the Stretcher are facing down. Place the Front Legs to Corner Block of the frame, and insert Side Stretcher into the Legs.
  - Insert the **JCBC Bolt (Long)** Bolt through a **Lock Washer**, a **Flat Washer** and the pre-drilled holes of Corner Block into the pre-drilled holes on the Front Leg, use the provided **Allen Key**. But do not fully tighten the bolts yet.
  - Insert **Pan Head Screw** into Side Stretcher through the pre-drilled holes, tighten with screw-driver.

### STEP 1

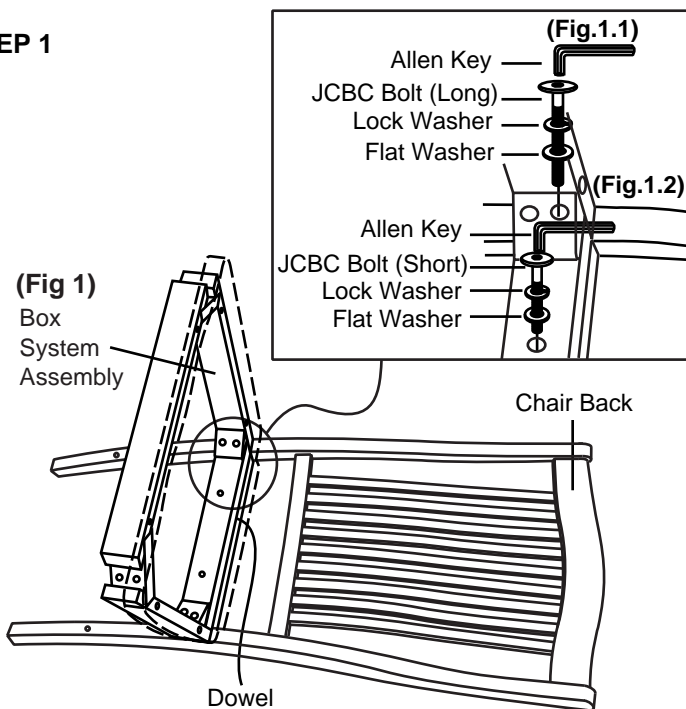

### STEP 2

Apply Glue and insert stretcher with screw holes facing down.

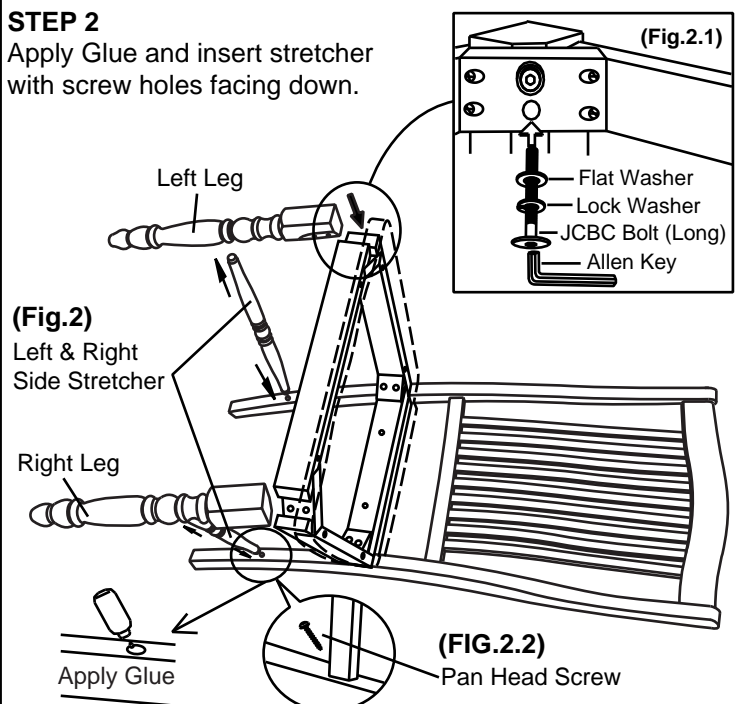

### STEP 3

Turn the chair upright. Check its balance and tighten all screws and bolts to complete the assembly.

